

Heat balance of a multistage spray-dryer: principles and example of application

Jean-Jacques BIMBENET^a, Pierre SCHUCK^{b*}, Michel ROIGNANT^c,
G rard BRUL c, Serge M JEAN^b

^a ENSIAA, 1 avenue des olympiades, 91744 Massy, France

^b Laboratoire de Recherches de Technologie Laiti re, INRA, 65 rue de Saint Briec,
35042 Rennes Cedex, France

^c D partement agro-alimentaire, ENSAR, 65 rue de Saint-Briec, 35042 Rennes Cedex, France

Abstract – The authors present the principles of isenthalpic air drying, the use in drying of the enthalpic diagram of air and mass and enthalpy balances. As an application of these principles, a pilot multistage spray-dryer, operating on skim milk, was experimentally studied. Air flow rates were measured by a hot wire anemometer at different positions of the air pipes. It was checked that the mass flow rate of air delivered by a fan was independent of air temperature. A thermohygrometer was used to measure the temperature and relative humidity of the air. The mass flow rate of concentrated skimmilk was estimated from the characteristics of the spraying nozzle. Introduction of air into the internal and external fluid beds was taken into account. From these data, the heat balance showed a difference between inputs and outputs of 2.9% which may be interpreted as heat losses and probable errors. The specific heat consumption was close to 4 900 kJ·kg⁻¹ of evaporated water. This overall value includes the rather low energetic efficiency of the small flow rates of air used in both fluid beds. This specific heat consumption corresponds to 2.1 times the latent heat of vaporisation of water at 70  C, i.e. a thermal efficiency of 48.8%. These figures represent a use of energy less efficient than in industrial dryers, which may be explained by the small size of the plant, operating at only 122 kg of concentrate and 70 kg of evaporated water per hour.

Spray-dryer / skimmilk / heat and mass balance

R sum  – Bilan  nerg tique d'une tour de s chage multiple effet. Les auteurs pr sentent les principes du s chage isenthalpique par l'air chaud, de l'utilisation du diagramme enthalpique de l'air humide et des bilans de chaleur et de mati re en s chage   l'air chaud. Ces principes sont appliqu s   l' tude exp rimentale d'un s choir pilote par pulv risation,   lits fluidis s interne et externe, traitant du lait  cr m . Les mesures ont  t  effectu es en r gime  tabli. Les d bits d'air ont  t  mesur s par

Communication at the 1st International Symposium on Spray Drying of Milk Products, Rennes, France, October 16–18, 2001.

* Correspondence and reprints

Tel.: 33 (0)2 23 48 53 22; fax: 33 (0)2 23 48 53 50; e-mail: schuck@rennes.inra.fr

des anémomètres à fil chaud, les teneurs en eau de l'air par des hygromètres et le débit de produit estimé à partir des caractéristiques de la buse. À partir de ces données, le bilan thermique donne un écart de 2,9 % entre les entrées et les sorties, explicable par des pertes de chaleur et les erreurs probables. La consommation énergétique massique calculée est de $4\,910 \text{ kJ}\cdot\text{kg}^{-1}$ d'eau évaporée, ce qui représente 2,1 fois la chaleur latente d'évaporation de l'eau à 70°C . La faible efficacité énergétique des lits fluidisés est incluse dans ces valeurs globales. Ces chiffres correspondent à une efficacité moindre que celle des séchoirs industriels, ce qui peut s'expliquer par la faible température moyenne des airs de séchage et la petite taille (70 kg d'eau évaporée par heure) de l'installation étudiée.

Séchoir par pulvérisation / séchage par atomisation / lait écrémé / bilan masse et énergie

1. INTRODUCTION

Drying, consisting of lowering water activity, is an efficient method of preservation of biological products, since it does not require severe heat treatment and allows storage at ambient temperature. Large amounts of liquid dairy products (skim and fat milk, whey, various fractions resulting from membrane and chromatographic separations) are dried in order to make feed, food and ingredients. Most of these powders are produced by spray-drying. In this technique, the liquid is sprayed in droplets of, e.g. $50 \mu\text{m}$, in a large drying chamber containing air heated to around 200°C . The temperature of the product itself is not raised much over the temperature of the exit air, i.e. under 100°C . Since the drying is very fast, a few seconds, the thermal damage is limited. Classical spray-dryers are associated with a fluid bed which usually agglomerates the fine powder coming from the drying chamber, completes its drying and cools it. In the recent models ("3 effects"), another fluid bed is integrated at the bottom of the drying chamber, with agglomeration and drying functions. The main drawback of drying operations in general is their consumption of energy, which, in spite of progress resulting, in the case of spray-drying, from this integrated fluid bed, remains around 1.5 to 2 times the latent heat of vaporisation of water. The "Energetic Specific Consumption, ESC" (Bimbenet [1]), in kJ per kg of evaporated water is powerful for dryers and the comparing effects of drying operating parameters. It is therefore

useful to evaluate the ESC of dryers to optimise the production and reduce the cost. It can be done mainly by an increase in the total solid of the concentrate, an increase in the inlet air temperature or a reduction of the outlet air temperature. The increase in the difference between the inlet and the outlet air temperatures reduces the ESC of dryers [5]. Before reducing this ESC, it is necessary to know the mass and energy balances. With the improvement of technology (the three-stage spray-dryer), the air circuits are more numerous. Thus, the mass and enthalpy balances are more complex to realise. There are no publications on this subject.

This paper shows an example of such measurements, through the calculation of mass and enthalpy balances with the use of the enthalpic diagram to visualise operating conditions.

2. MATERIALS AND METHODS

The drying equipment was a pilot (GEA-NIRO, Saint-Quentin-en-Yvelines, France) 3-effect spray-dryer (evaporating capacity: $70 \text{ kg}\cdot\text{h}^{-1}$) as represented in Figure 1 (from Schuck et al. [4]), operating on skimmilk.

Air flow rates at different points (Fig. 2) were measured with hot wire anemometers at 5 positions of the section of straight cylindrical ducts, according to Masters [3]. The weighted average of velocities multiplied by the total cross section gave the

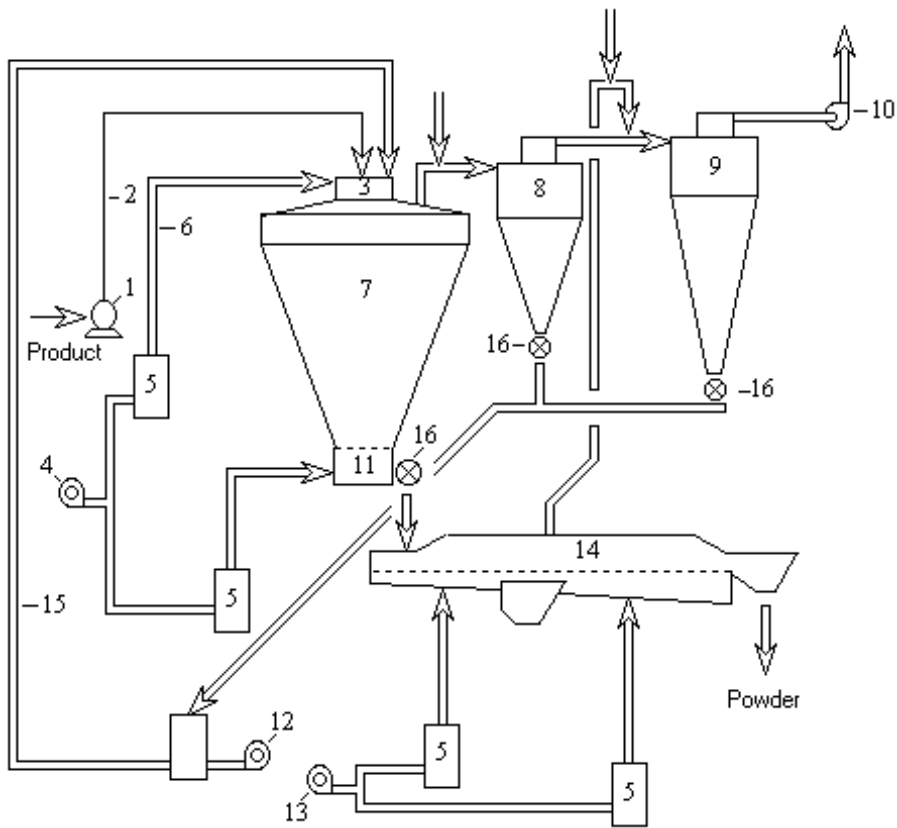

- | | |
|---------------------|--|
| 1 – Feed pump | 9 – Secondary cyclone |
| 2 – Feed flow | 10 – Outlet air fan |
| 3 – Sprayer | 11 – Integrated fluid bed |
| 4 – Inlet air fan | 12 – Pressure conveying system |
| 5 – Air heater | 13 – Vibro-fluidizer air fan |
| 6 – Drying air | 14 – Vibro-fluidizer |
| 7 – Drying chamber | 15 – Fines reincorporating into the atomization zone |
| 8 – Primary cyclone | 16 – Rotary valve |

Figure 1. Multiple effect spray-dryer, Bionov, Rennes, France.

volume flow rate. Three replications were performed, with a standard deviation of 2%. These measurements were done at ambient temperature. It was checked that upstream (i.e. before the heaters) the mass

flow rate was not modified when air was heated up to 200 °C. This was due to opposite effects of temperature on pressure losses in the equipment, through decreased air density and viscosity and increased

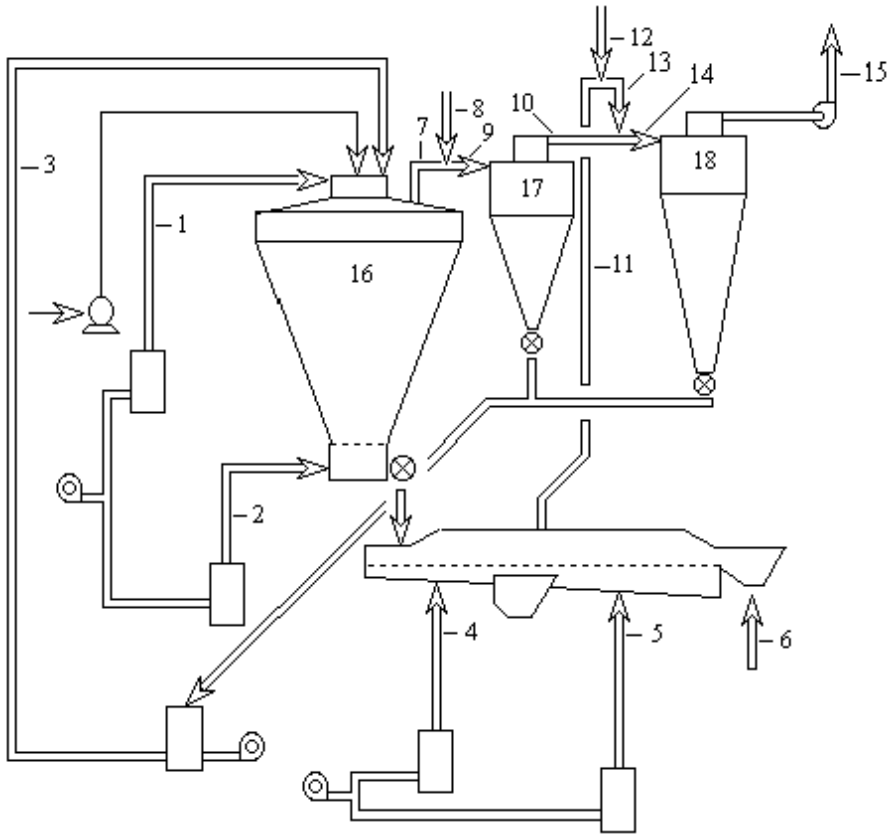

- | | |
|---|--|
| 1 – Inlet air | 10 – Outlet air |
| 2 – Integrated fluid bed air | 11 – Outlet vibro-fluidizer air (= 4 + 5 + 6) |
| 3 – Pressure conveying system air | 12 – Auxiliary surrounding air for the primary cyclone |
| 4 – First part of vibro-fluidizer air (VF 1) | 13 – (= 11 + 12) |
| 5 – Second part of vibro-fluidizer air (VF 2) | 14 – Outlet air (= 10 + 13) |
| 6 – Surrounding air | 15 – Outlet (= 14) |
| 7 – Outlet air (= 1 + 2 + 3) | 16 – Drying chamber |
| 8 – Auxiliary surrounding air for the primary cyclone | 17 – Primary cyclone |
| 9 – Outlet air (= 7 + 8) | 18 – Secondary cyclone |

Figure 2. Measurement points of air mass flow rates and temperatures.

velocity. Therefore, we considered that the mass flow rate of dry air delivered by the fans was not significantly modified by temperature.

The mass balances of water were calculated from the data of equipment manufacturers, who consider that 99% of water is evaporated in the tower (93% in the spray and 6% in the integrated fluid bed) and 1% in the external fluid bed, according to Sougnez [5] and Westergaard [6].

Air-specific enthalpies were read on a Mollier-Ramzine enthalpic diagram (Fig. 4) or calculated by the classical formula:

$H = [1.01 \theta + Y(2.494 + 1.92 \theta)] \cdot 10^3$, with origin of enthalpies at 0 °C.

Specific heat of concentrate:

$c_p = 3.0 \text{ kJ} \cdot \text{kg}^{-1} \cdot \text{°C}^{-1}$ and of powder:

$c_p = 1.5 \text{ kJ} \cdot \text{kg}^{-1} \cdot \text{°C}^{-1}$ (Kessler [2]).

More details are given by Schuck et al. [4].

3. RESULTS AND DISCUSSION

3.1. Results of measurements

The results of the measurements are given in Table I. The other flow rates (n° 9 – 10 – 13 – 14) could not be measured for practical reasons. They were calculated on the basis of dry air mass balances as explained in Section 3.2.

Inlet air temperature (before heating) was 25 °C and relative humidity 40%, resulting in a water content $Y = 0.008 \text{ kg water} \cdot \text{kg}^{-1} \text{ dry air}$, according to the enthalpic diagram (point FA, for fresh air).

The data concerning the product (concentrate and powder) were taken from experiments conducted earlier on the same plant (Schuck et al. [4]):

– concentrate mass flow rate: $121.8 \text{ kg concentrate} \cdot \text{h}^{-1}$, solid concentration: $395.4 \times 10^{-3} \text{ kg solids} \cdot \text{kg}^{-1} \text{ concentrate}$, temperature: 40 °C,

Table I. Results of measurements.

Positions	Dry air mass flow rate (kg dry air·h ⁻¹)	Temperature (°C)
1	1718	200
2	672	70
3	81	25
4	225	50
5	237	35
6	136	25
7	2567	-
8	255	25
11	614	-
12	0	-
15	3404	69

– powder: $57.2 \times 10^{-3} \text{ kg water} \cdot \text{kg}^{-1} \text{ powder}$ (i.e. $942.8 \times 10^{-3} \text{ kg solids} \cdot \text{kg}^{-1} \text{ powder}$), temperature: 30 °C.

3.2. Mass balances

Figure 3 has been used to give an easier view of the system for mass and enthalpy balance calculations.

We calculate the total evaporation:

Solids flow rate in the concentrate is: $121.8 \times 0.3954 = 48.2 \text{ kg solids} \cdot \text{h}^{-1}$.

The powder mass flow rate \dot{m}_p is such as $\dot{m}_p \times 0.9428 = 48.2 \text{ kg solids} \cdot \text{h}^{-1}$, based on the hypothesis of constant solids flow rate.

So: $\dot{m}_p = 51.1 \text{ kg} \cdot \text{h}^{-1}$.

The evaporation rate is $121.8 - 51.1 = 70.7 \text{ kg water} \cdot \text{h}^{-1}$.

Evaporation rate in the tower: 99% of the total, i.e.: $0.99 \times 70.7 = 70.0 \text{ kg water} \cdot \text{h}^{-1}$.

Evaporation rate in the external fluid bed: 1% of the total, i.e.: $0.01 \times 70.7 = 0.7 \text{ kg water} \cdot \text{h}^{-1}$.

3.2.1. On the tower itself

Since measurements have been made on inlets and outlets only, there is no possibility

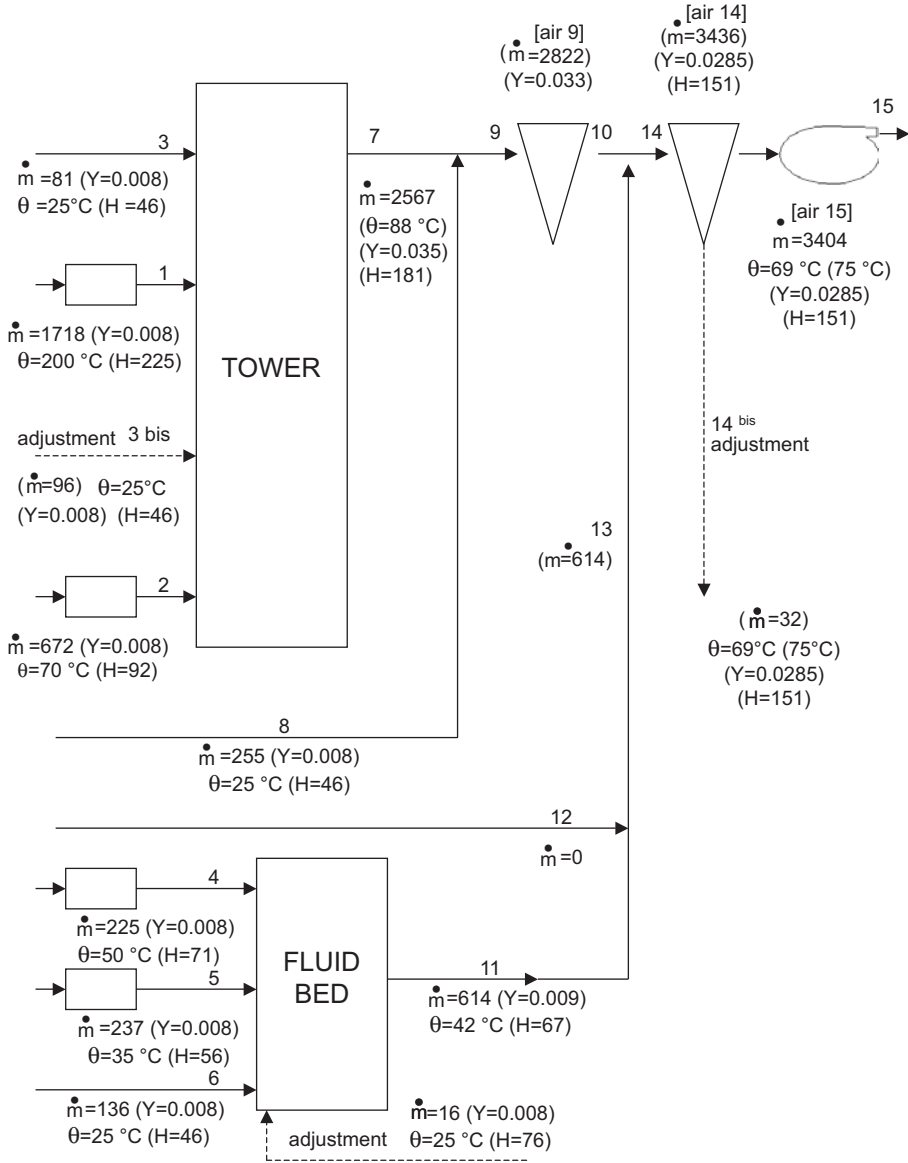

Figure 3. Characteristics of air in the system.

No parentheses: measured values.

In parentheses: calculated values.

\dot{m} is in kg dry air (DA)·h⁻¹; Y in kg water (W)·kg⁻¹ DA; H in kJ·kg⁻¹ DA.

of considering drying in the spray zone and in the internal fluid bed separately.

– Dry air flow rates:

Total inlet = points 1 + 2 + 3: $\dot{m} = 1718 + 672 + 81 = 2471 \text{ kg dry air}\cdot\text{h}^{-1}$.

Outlet = point 7, measured: $\dot{m} = 2567 \text{ kg dry air}\cdot\text{h}^{-1}$.

A difference of $96 \text{ kg dry air}\cdot\text{h}^{-1}$ appears (i.e. 4%), originating from measurement errors, but also from a possible uncontrolled air inlet, since the whole equipment is in depression. To adjust the balance, we add a fictitious (and/or possibly physical) inlet of fresh air (3bis).

– Water mass flow rates (calculated figures are rounded up to a reasonable number of significant digits):

In inlet air: $\dot{m}_w = 2567 \times 0.008 = 20.5 \text{ kg water}\cdot\text{h}^{-1}$.

Water in air outlet (point 7): $\dot{m}_w = 20.5 + 70.0 = 90.5 \text{ kg water}\cdot\text{h}^{-1}$.

Water content in air outlet:

$Y = 0.008 + (70.0 / 2567) = 0.008 + 0.027 = 0.035 \text{ kg water}\cdot\text{kg}^{-1} \text{ dry air}$, also equal to $90.5 : 2567$.

We notice that every kg of dry air carries 27 g of water extracted from the product.

3.2.2. On the external fluid bed

– Dry air flow rates:

Total inlet = points 4 + 5 + 6: $\dot{m} = 225 + 237 + 136 = 598 \text{ kg dry air}\cdot\text{h}^{-1}$.

Outlet = point 7 $\dot{m}_p = 614 \text{ kg dry air}\cdot\text{h}^{-1}$.

Similarly as above, we add an adjustment flow rate (6bis) of fresh air: $16 \text{ kg dry air}\cdot\text{h}^{-1}$ (about 2.5% of the total inlet).

– Water flow rates:

In air inlet: $\dot{m}_w = 614 \times 0.008 = 5.0 \text{ kg water}\cdot\text{h}^{-1}$.

Water in air outlet (point 11): $\dot{m}_w = 5.0 + 0.7$ rounded to $5.5 \text{ kg water}\cdot\text{h}^{-1}$.

Water content in air outlet (point 11):

$Y = 0.008 + (0.7/614) = 0.008 + 0.001 = 0.009 \text{ kg water}\cdot\text{kg}^{-1} \text{ dry air}$.

It shows that the external fluid bed has a very limited drying action: only 1 g of evaporated water per kg of dry air.

3.2.3. On the cyclone section

– Dry air flow rates:

Points 9 or 10 = points 7 + 8: $\dot{m} = 2567 + 255 = 2822 \text{ kg dry air}\cdot\text{h}^{-1}$.

Point 13 = points 11 + 12: $\dot{m} = 614 + 0 = 614 \text{ kg dry air}\cdot\text{h}^{-1}$.

Points 14 and 15 = points 10 + 13: $\dot{m} = 2822 + 614 = 3436 \text{ kg dry air}\cdot\text{h}^{-1}$.

Compared to the measured flow rate ($\dot{m} = 3404 \text{ kg dry air}\cdot\text{h}^{-1}$), there appears to be an excess of $32 \text{ kg dry air}\cdot\text{h}^{-1}$ (less than 1%). We then add an adjustment outlet flow (14bis).

– Water flow rates:

Points 9 or 10 = points 7 + 8: $\dot{m}_w = 90.5 + (255 \times 0.008) = 92.5 \text{ kg water}\cdot\text{h}^{-1}$.

Water content in air 9 or 10: $Y = 92.5 / 2822 = 0.033 \text{ kg water}\cdot\text{kg}^{-1} \text{ dry air}$.

Point 14 = points 10 + 13: $\dot{m}_w = 92.5 + 5.5 = 98 \text{ kg water}\cdot\text{h}^{-1}$.

Water content in air 14 or 14bis or 15: $Y = 98 / 3436 = 0.0285 \text{ kg water}\cdot\text{kg}^{-1} \text{ dry air}$.

Point 15 = points 14 – 14bis: $\dot{m}_w = 98 - (32 \times 0.0285) = 97 \text{ kg water}\cdot\text{h}^{-1}$.

3.3. Enthalpy balances

3.3.1. On the tower itself

– Air inlet: the enthalpy flow rate \dot{H} (in $\text{kJ}\cdot\text{h}^{-1}$), is the sum of inlet enthalpies (points 1 + 2 + 3 + 3bis):

$\dot{H} = (1718 \times 225) + (672 \times 92) + (81 \times 46) + (96 \times 46) = 457 \times 10^3 \text{ kJ}\cdot\text{h}^{-1}$.

The fictitious mixture of these inlets would have a specific enthalpy of $H = 457 \times 10^3 / 2567 = 178 \text{ kJ}\cdot\text{kg}^{-1} \text{ dry air}$. According to the enthalpic diagram (Fig. 4), taking

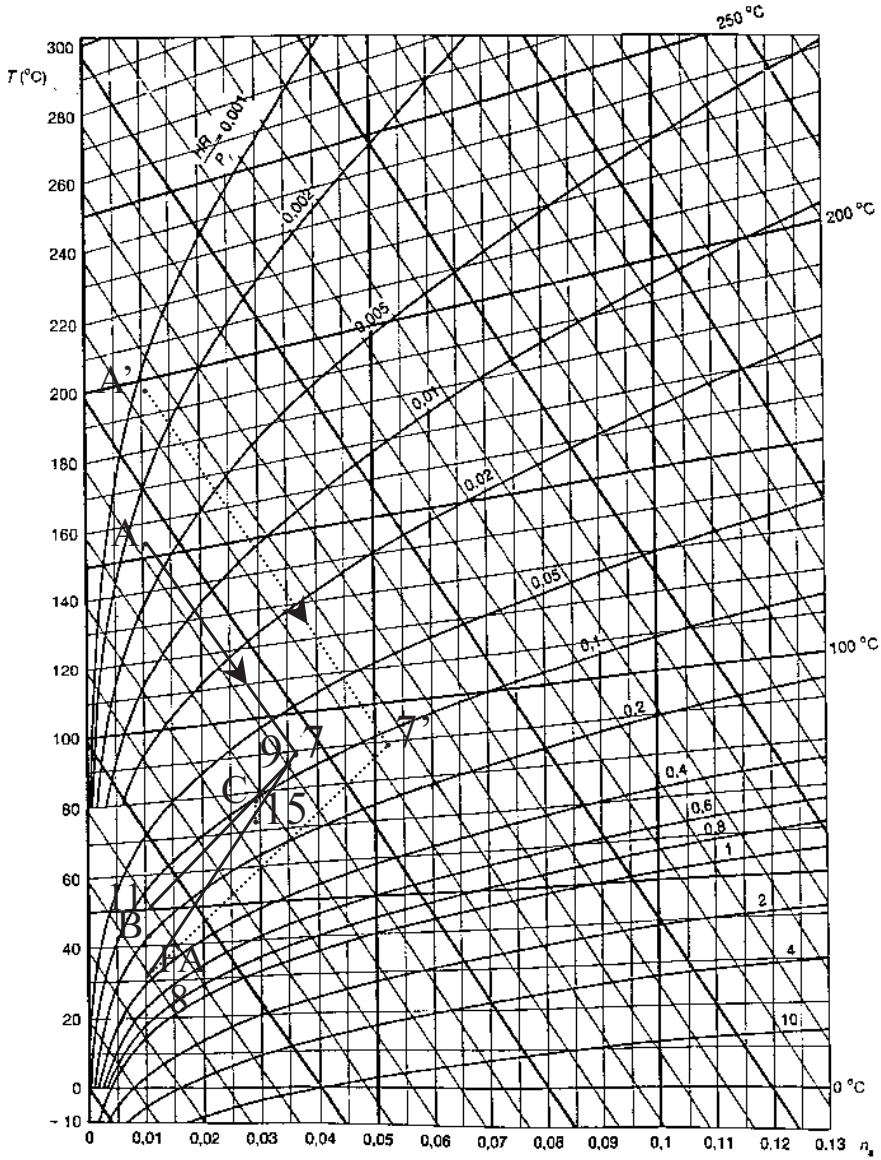

Figure 4. Enthalpic Mollier-Ramzine diagram of wet air. (HR: Relative humidity; $P_r = 1$ for atmospheric pressure).

into account the value of Y , this mixture would be represented by the point A, where we read a temperature of 153 °C (which is rather low for this type of dryer).

– Concentrate inlet: $\dot{H} = \dot{m}.c_p.\theta = 121.8 \times 3.0 \times 40 = 14.5 \times 10^3 \text{ kJ}\cdot\text{h}^{-1}$.

– Powder outlet. We suppose here that all the powder leaves the tower towards the external fluid bed (we neglect powder outlets of cyclons) and we suppose it to be at 80 °C (a mis-evaluation of this temperature has only a slight effect on the enthalpy balance) and containing the 0.7 kg·h⁻¹ of water to be evaporated in the external fluid bed:

$$\dot{H} = \dot{m}.c_p.\theta = (51.1 + 0.7) \times 1.5 \times 80 = 6 \times 10^3 \text{ kJ}\cdot\text{h}^{-1}.$$

– The enthalpy balance of the tower writes:

$$(457 \times 10^3) + (14.5 \times 10^3) = (\dot{H}_{\text{outlet air}}) + (6 \times 10^3) \text{ kJ}\cdot\text{h}^{-1}.$$

We then have for the outlet air 7:

$$\dot{H} = 465.5 \text{ kJ}\cdot\text{h}^{-1}.$$

corresponding to a specific enthalpy of $H = 465.5 \times 10^3 / 2567 = 181 \text{ kJ}\cdot\text{kg}^{-1}$ dry air and (with $Y = 0.035 \text{ kg water}\cdot\text{kg}^{-1}$ dry air), a temperature of 88 °C was read on the diagram.

3.3.2. On the external fluid bed

Similarly, we write:

– Air inlet (point 4 + 5 + 6 + 6bis):

$$\dot{H} = (225 \times 71) + (237 \times 56) + (136 \times 46) + (16 \times 46) = 36 \times 10^3 \text{ kJ}\cdot\text{h}^{-1}.$$

The specific enthalpy of this fictitious mixture would be:

$$H = 36 \times 10^3 / 614 = 59 \text{ kJ}\cdot\text{kg}^{-1} \text{ dry air}.$$

We could therefore (using $Y = 0.008$) position it in B on the enthalpic diagram, and read a temperature of 39 °C.

– Powder, entering at 80 °C and leaving at 30 °C:

$$\text{inlet } \dot{H} = \dot{m}.c_p.\theta = 52 \times 1.5 \times 80 = 6 \times 10^3 \text{ kJ}\cdot\text{h}^{-1}$$

$$\text{outlet } \dot{H} = 51.1 \times 1.5 \times 30 = 2.5 \times 10^3 \text{ kJ}\cdot\text{h}^{-1}$$

which adds $3.5 \times 10^3 \text{ kJ}\cdot\text{h}^{-1}$ to the inlet flux of enthalpy.

– Air outlet (point 11):

$$\dot{H} = (36 \times 10^3) + (3.5 \times 10^3) = 39.5 \times 10^3 \text{ kJ}\cdot\text{h}^{-1}$$

with a specific enthalpy of: $H = 39.5 \times 10^3 / 614 = 64 \text{ kJ}\cdot\text{kg}^{-1}$ dry air. This value, as well as the water content ($Y = 0.009$) allows us to position the point 11 on the diagram and read a temperature of 43 °C.

The shortness of the path from point B to this point 11 shows that the cooling and drying effects of this external fluid bed on the product have a very small influence on the global water and enthalpy balances of the whole system.

3.3.3. On the cyclons section

We have neglected the flows of powder in this part.

– Air 9 or 10 = points 7 + 8:

$$\dot{H} = (465.5 \times 10^3) + (255 \times 46) = 477.5 \times 10^3 \text{ kJ}\cdot\text{h}^{-1}.$$

– Air 14 = points 10 + 13:

$$\dot{H} = (477.5 \times 10^3) + (614 \times 64) = 517 \times 10^3 \text{ kJ}\cdot\text{h}^{-1},$$

with $H = (517 \times 10^3) / 3436 = 150 \text{ kJ}\cdot\text{kg}^{-1}$ dry air.

– Air 15 = points 14 – 14bis:

$$\dot{H} = 517 \times 10^3 (32 \times 150) = 512 \text{ kJ}\cdot\text{h}^{-1}.$$

Therefore, this air outlet ($H = 150 \text{ kJ}\cdot\text{kg}^{-1}$ dry air, $Y = 0.0285$) has a calculated temperature of 74 °C (point C), to be compared with a measured one of 69 °C (corresponding to $H = 146$ point 15).

It appears therefore that there are enthalpy losses + / – errors of:

$$\dot{H} = 3436 (151 - 146) = 17 \times 10^3 \text{ kJ}\cdot\text{h}^{-1}.$$

3.3.4. Global enthalpy balance

Table II shows that the enthalpy balance for the whole system (tower and fluidised bed) is equilibrated.

3.4. Energetic efficiency

ESC (Energetic Specific Consumption), the ratio of consumed energy to evaporated water, is useful for comparing dryers or drying parameters with respect to energy.

The energy consumed $\Delta\dot{H}$ to heat different inlet airs is calculated (Tab. III) as product of dry air mass flow rates and enthalpy differences ΔH . The results are that $339 \text{ kJ}\cdot\text{h}^{-1}$ are spent for the tower (10% of this for the internal fluid bed) and only 8×10^3 for the internal fluid bed.

Global ESC:

$$\text{ESC} = (347 \times 10^3) / 70.7 = 4910 \text{ kJ}\cdot\text{kg}^{-1} \text{ evaporated water.}$$

We may dissociate:

$$\text{ESC (tower): } (339 \times 10^3) / 70.0 = 4810 \text{ kJ}\cdot\text{kg}^{-1} \text{ evaporated water.}$$

$$\text{ESC (external fluid bed): } (8 \times 10^3)/0.7 = 11400 \text{ kJ}\cdot\text{kg}^{-1} \text{ evaporated water.}$$

This last value is very high, which is normal: the external fluid bed is not devised to be an efficient dryer.

If we consider that water evaporation took place at around $70 \text{ }^\circ\text{C}$, corresponding to a latent vaporisation heat of $2330 \times 10^3 \text{ kJ}\cdot\text{kg}^{-1}$ water, we spent 2.1 times this theoretical value (efficiency: $1/2.1 = 48\%$).

These figures are worse than the industrial ones: why is it so?

The heat loss of $17 \times 10^3 \text{ kJ}\cdot\text{h}^{-1}$ represents 5% of the total spent energy, which is also rather high, due to the small equipment size (therefore a high ratio surface/volume) and possible low insulation, but this cannot explain 52% of losses.

The only possible explanation is that it takes $3436/70.7 = 49 \text{ kg}$ of dry air to evaporate 1 kg of water. This air enters the process at $25 \text{ }^\circ\text{C}$ and is rejected at $69 \text{ }^\circ\text{C}$, which corresponds to a considerable loss of energy. This figure (49 kg dry air per kg water) is higher than in industry due to the relatively low ($153 \text{ }^\circ\text{C}$) air inlet temperature.

This can be shown by an approximate calculation on the tower alone, using the enthalpic diagram, on the basis of the same evaporation rate. If the air inlet temperature was $200 \text{ }^\circ\text{C}$ (point A') instead of $153 \text{ }^\circ\text{C}$ and the outlet maintained at the same calculated value of $88 \text{ }^\circ\text{C}$ (point 7'), this outlet air would contain $Y = 0.052 \text{ kg water}\cdot\text{kg}^{-1}$ dry air (instead of 0.035). Every kg of dry air would carry: $0.052 - 0.008 = 0.044 \text{ kg}$ of water (instead of 0.027), which corresponds to: $1 / 0.044 = 23 \text{ kg}$ of dry air to evaporate 1 kg of water (instead of $1 / 0.027 = 37 \text{ kg}$). The mass flow rate would be: $70.0 / 0.044 = 1590 \text{ kg dry air}\cdot\text{h}^{-1}$ (instead of 2567), and the heating energy: $\dot{H} = 1590 (225 - 46) = 285 \times 10^3 \text{ kJ}\cdot\text{kg}^{-1}$ dry air (instead of 339×10^3 , cf. Tab. III, sum of the heating energies of airs 1 and 2). The ESC

Table II. Global enthalpy balance ($\text{kJ}\cdot\text{h}^{-1}$).

Inlets		Outlets	
Air to tower	457×10^3	Air outlet ($69 \text{ }^\circ\text{C}$)	
		$3436 \times 146 =$	501×10^3
Air to external fluid bed	37×10^3	Powder	2.5×10^3
Air 8	12×10^3	Loss	17×10^3
Concentrate	14.5×10^3		
Total inlets	520.5×10^3	Total outlets	520.5×10^3

Table III. Consumed energy (kJ·h⁻¹).

	Dry air mass flow rate (kg dry air·h ⁻¹)	ΔH (kJ·kg ⁻¹ dry air)	$\Delta \dot{H}$ (kJ·h ⁻¹)
Air 1	1718	225 – 46	308 × 10 ³
Air 2	672	92 – 46	31 × 10 ³
Air 4	225	71 – 46	6 × 10 ³
Air 5	237	56 – 46	2 × 10 ³
Total			347 × 10 ³ kJ·h ⁻¹

for this tower would become: $285 \times 10^3 / 70.0 = 4071$ kJ·kg⁻¹ water, instead of 4810. In fact, the comparison of the slopes of the lines FA-7 and FA-7' gives an idea of the expectable improvement in this change of parameter (Bimbenet [1]).

4. CONCLUSION

This study shows how to establish mass and heat balances on drying equipment and what conclusions may be drawn from that.

The global air mass flow rate is approximately correct, since the algebraic sum of flow rates adjustment is an inlet of 80 kg dry air·h⁻¹ (2.5% of total inlets), part of it being probably explainable by real air inlets. This shows that measuring air flow rates on "cold" equipment seems to be acceptable.

After having done these calculations, we realised that more air temperature measurements would have been useful to validate the calculations at each step.

The enthalpic diagram of air here proves its interest in the fast estimations necessary for heat and mass balances and in the discussions about Energy Specific Consumption (ESC).

It is also shown also how this ESC is sensitive to inlet air temperature. It would be

easy to show similarly the influence of exit air temperature, of air recycling, etc.

Symbols

c_p	specific heat	kJ·kg ⁻¹ ·°C ⁻¹
H	specific enthalpy of air	kJ·kg ⁻¹ dry air
\dot{H}	enthalpy flow rate	kJ·h ⁻¹
\dot{m}	mass flow rate	kg·h ⁻¹
Y	water content of air	kg water·kg ⁻¹ dry air
θ	temperature	°C

REFERENCES

- [1] Bimbenet J.J., Criteria of energetic performance for convection-type dryers, in: Mujumdar A.S. (Ed.), *Drying '82*, Hemisphere Publ. Corp., Washington, USA, 1982, pp.121–128.
- [2] Kessler H.G., *Food engineering and dairy technology*, Verlag A. Kessler, Freising, Germany, 1981.
- [3] Masters K., *Spray-drying*, Longman Sci. & Technic., Harlow, UK, 1991.
- [4] Schuck P., Roignant M., Brulé G., Méjean S., Bimbenet J.J., Caractérisation énergétique d'une tour de séchage par atomisation multiple effet, *Ind. Alim. Agric.* 115 (1998) 9–14.
- [5] Sougnez M., Évolution du séchage par atomisation, *Chim. Mag.* 12 (1983) 1–4.
- [6] Westergaard V., *Milk powder technology, Evaporation and spray drying*, Niro A/S, Copenhagen, Denmark, 1994.